

STEAMIST®

Steam Generator

Models: SM-12/ SM-12-IM

Features

5-year parts warranty - 2-year labor warranty
 Generator typically can be installed up to 25 ft. from the bathing area
 Diagnostic LED Displays
 Stainless Steel Construction
 Solid-State Circuitry

Codes/Standards

UL 499
 UL/CUL Listed
 City of LA - Approved
 City of New York - M.E.A. Approved
 State of Mass. Approved

Important

In order for the InstaMist feature to function on model SM-12-IM, water must always be in the tank. For this reason the factory installed Auto Drain is NOT available with any InstaMist generators.

System-12 / System-12-IM

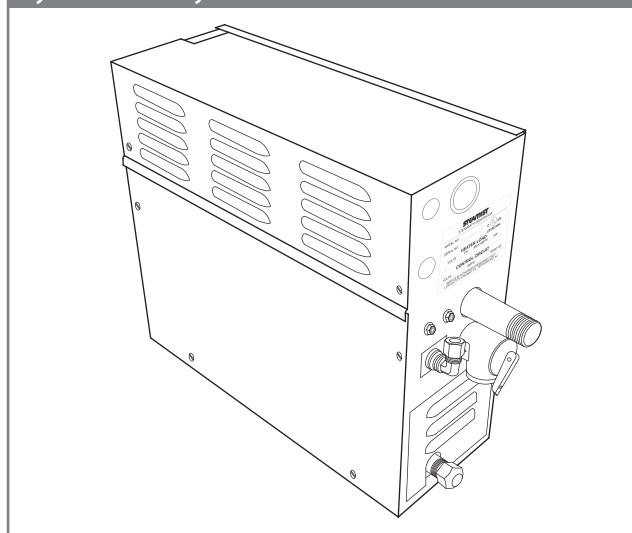

Steam Generator Specification Chart

Model Number	Product Number	KW Rating	Max. Cu. Ft. Range*	Volts/Phase/Max. Amps	Wire Size 90°C Copper AWG	Line Fuse	Dimensions L x W x H
SM-12	1200	12	450	240/1/50	6	70	20" x 8¼" x 18½"
	1201			208/1/58	4	80	
	1202			240/3/29	8	40	
	1203			208/3/33	8	45	
SM-12-IM	1200-IM	12	450	240/1/50	6	70	20" x 8¼" x 18½"
	1201-IM			208/1/58	4	80	
	1202-IM			240/3/29	8	40	
	1203-IM			208/3/33	8	45	

*Refer to sizing guidelines to accurately determine the proper size generator for the installation.

Required Equipment

TC-110, TC-135, TC-125, TC-150, DSC-425, or DSP Controls

Required Electrical Service

Dedicated circuit required: See Specification Chart for proper electrical requirements

Product Information

Dedicated circuit required: See Specification Chart for proper electrical requirements

Water Supply - ¾" Compression Fitting

Steam Line - ¾" Brass BPT male thread

Pressure Relief Valve - ¾" NPT female thread

Drain Line - Capped ½" Brass NPT male thread. Auto Drain ready except on InstaMist (IM) models.

Generator

Weight - 52 lbs.

Installation Notes

Steam Generators can be typically mounted within 25 ft. of the bathing area.

Steam Generators should be accessible for service.

Do not install generators outside, in moist, humid area or in an area where parts may freeze or corrode.

Steamhead to be mounted 18" above floor or 6" above rim of tub and as far from the seating area as possible.

Rough-in Notes

Access: 28" W x 18" D x 24" H (35" W with Auto Drain)

Dimensional Drawing

Model: SM-12 / SM-12-IM

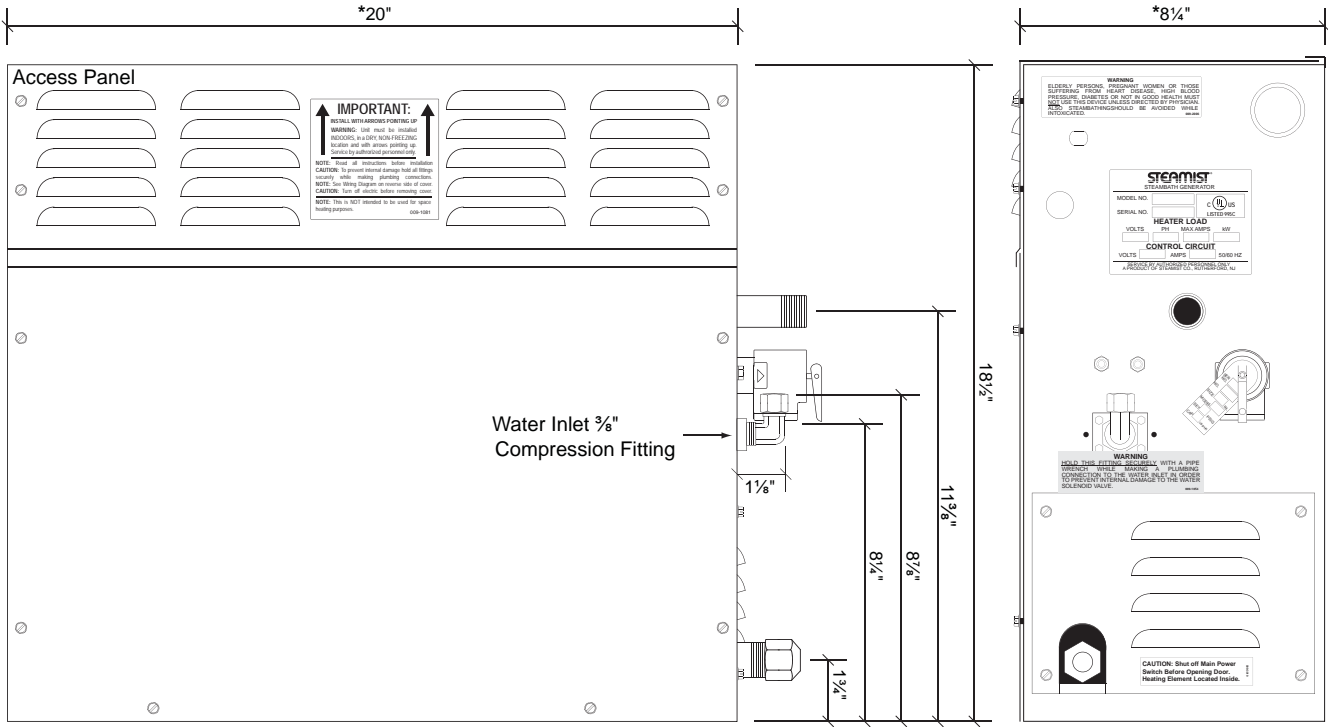

Front Access

Front Side View

*Add 1/4" to the dimension for the louvers

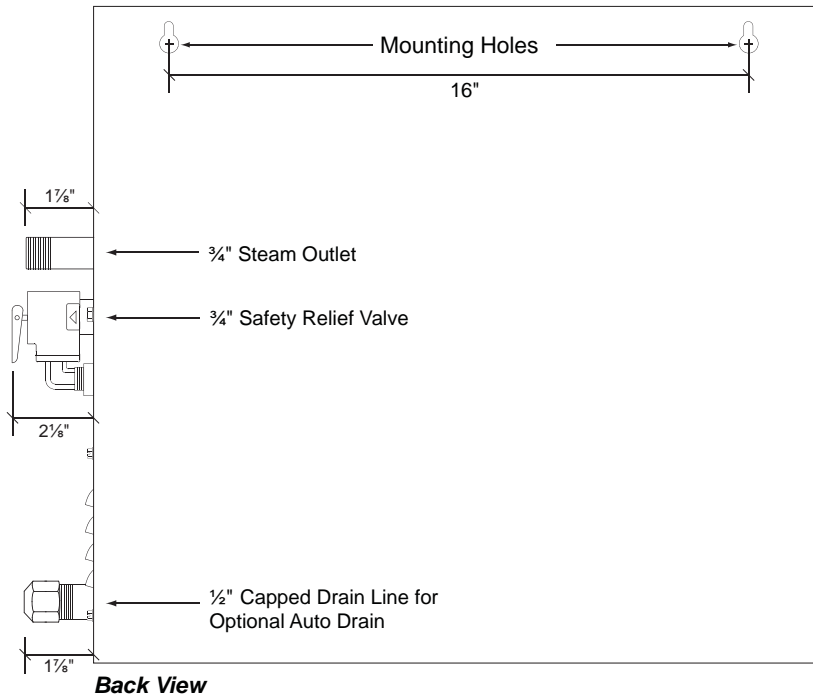

Back View

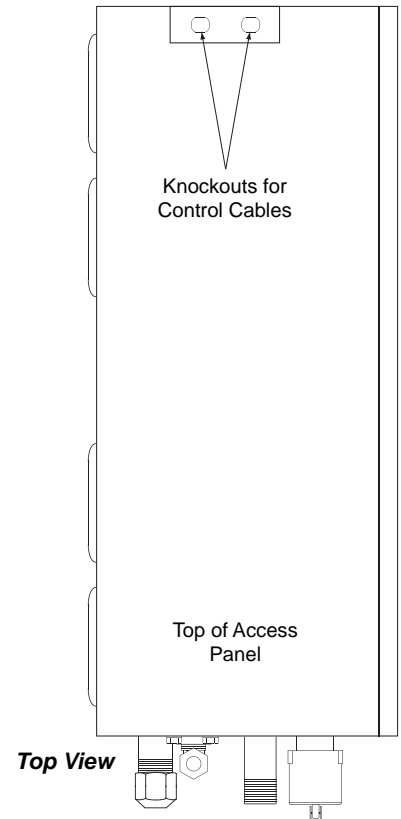

Top View